

Fan Coil Control Module MH-S230-4A



Important Safety Instruction

- ⚠ Read the instructions before starting up the unit!
 - ⚠ This product is not a toy. Keep out of reach of children and animals!
 - ⚠ Do not expose the device to moisture, water or other liquids. Do not place liquids near or on the device!
 - ⚠ Do not attempt to disassemble, repair or modify the device yourself!
- This product is for indoor use only. Do not use outdoors!

⚠ **CAUTIONS!**
Use Copper Conductors Only.

⚠ **CAUTIONS!**
Risk of Electric Shock - More than one disconnect switch may be required to de-energize the equipment before servicing.

Installation

Important!

- A qualified electrician with the understanding of wiring diagrams and knowledge of electrical safety should complete installation following the instructions.
- Before installation, please confirm the real voltage complying with the device's specification. Cut off any power supply to secure the safety of people and device.
- During installation, protect the device from any physical damage by dropping or bumping. If happens, please contact the supplier for maintenance.
- Keep the device away from acid-base and other corrosive solids, liquids, gases, to avoid damage.
- Avoid overexertion during operation, to protect device from mechanical damage.
- Read all instructions and documentation and save for future reference.

⚠ **CAUTION: Cut off power supply at circuit breaker or fuse before installation to avoid fire, shock or death!**

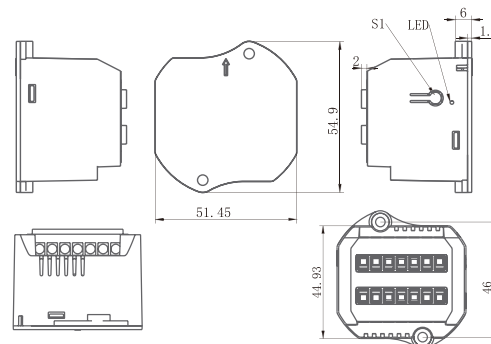
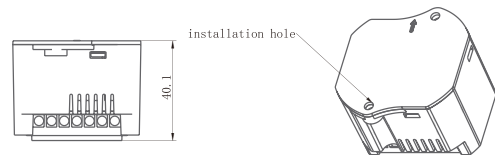

Wiring Diagram

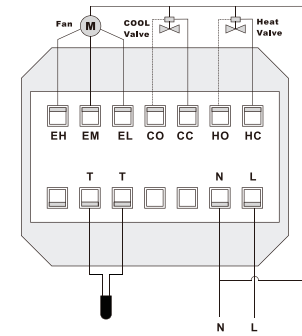

Operation

1. Included or Excluded from Z-Wave network

-Set the gateway into Inclusion or Exclusion mode, press S1 button of MH-S230-4A 3 times, MH-S230-4A enters learning mode and complete Inclusion or Exclusion process.

2. Associated with MH2910 thermostat

-Put MH2910's ID into the 2nd Association Group of MH-S230-4A.
-When the configuration parameter of the MH-S230-4A is set to 1 and the working mode/setpoint/fan mode/temperature unit/working state/fan state of the MH-S230-4A is changed, MH-S230-4A sends the changed data to all devices associated in the 2nd Associated Group.
-When the configuration parameter of the MH-S230-4A is set to 0 and the working state/fan state of MH-S230-4A are changed, MH-S230-4A sends the changed data to all devices associated in the 2nd Associated Group.

3. Off network protection output function

-When MH-S230-4A does not receive the reported room temperature value of MH-2910 within a certain period of time, MH-S230-4A will turn off the cooling and heating valves and fan output (invalid for when the MH-S230-4A is in ventilation mode). The timing time is set by parameters.

4. In the application scenario of 1 MH-2910 and multiple MH-S230-4A, to synchronize the operating modes/setpoint/fan mode of all MH-S230-4A and MH2910:

- Associate all the NOID of MH-S230-4A with the 2nd Association Group of MH2910.
- Set the 2nd Association Group of each MH-S230-4A to associate all MH-S230-4A except itself and a MH2910, and set the No. 3 parameter of MH-S230-4A to 1 (default is 1).

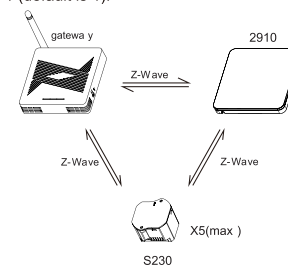

5. In the application scenario of 1 MH2910 and multiple MH-S230-4A, each MH-S230-4A needs standalone setpoint and fan mode:

- Associate all the NOID of MH-S230-4A with the 2nd Association Group of MH2910.
- If the state of MH-S230-4A needs to be synchronized to MH2910, associate MH2910 with the 2nd Association Group of MH-S230-4A and set parameter 3 of MH-S230-4A to 0.

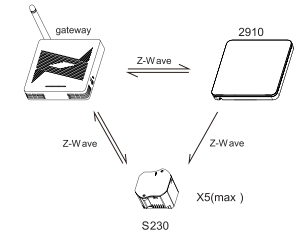

6. In the application scenario of A2 multi sensor and MH-S230-4A, do not require local operation to set the temperature:

- Associate all MH-S230-4A NOID to the 2nd Association Group of A2 multi sensor.

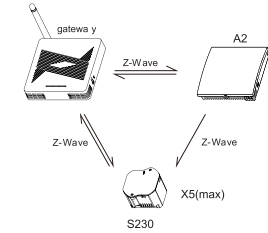

• Association Group

AG identifier	Max Node ID	Command Classes	Trigger situation
1	1	COMMAND_CLASS_SENSOR_MULTILEVEL_V5, SENSOR_MULTILEVEL_REPORT_V5	The change between detected temperature and last reported temperature is greater than the value set by parameter 2
		COMMAND_CLASS_THERMOSTAT_MODE_V2, THERMOSTAT_MODE_REPORT	Device mode changes
		COMMAND_CLASS_THERMOSTAT_OPERATING_STATE, THERMOSTAT_OPERATING_STATE_REPORT	Device status changes
		COMMAND_CLASS_THERMOSTAT_SETPOINT_V2, THERMOSTAT_SETPOINT_REPORT_V2	Set point value changes
		COMMAND_CLASS_THERMOSTAT_FAN_MODE, THERMOSTAT_FAN_MODE_REPORT	Fan mode changes
		COMMAND_CLASS_THERMOSTAT_FAN_STATE, THERMOSTAT_FAN_STATE_REPORT	Fan status changes
		COMMAND_CLASS_DEVICE_RESET_LOCALLY, DEVICE_RESET_LOCALLY_NOTIFICATION	Restore the factory setting

Specification

- Power Supply: AC90-250V, 50/60Hz
- Resistive Load: max 3A
- Self Consumption: ≤1W
- Working Environment: 0 ~ 55°C ; <70% RH (Non-condensation)
- Dimension: 55* 51.5*40mm
- Temperature setting range: 5~37°C
- Simple installation process
- Non-volatile memory, working state saved when power failure
- Intelligent on/off control of 3-speed fan, electric (ball) valve or air-valve

• Modules can do association to control multiple fan coil units

• Z-Wave Frequency: All frequency available



• Declaration of Conformity

CE Hereby, we declare that the device is in compliance with the essential requirements and other relevant provisions of Directive 2014/53/EU.

• WEEE Directive Compliance

The device marked with this symbol should not be disposed of with household waste. It is the user's responsibility to deliver the used appliance to a designated recycling point.

• Z-Wave Compliance

The module is a fully compatible Z-Wave Plus device.



AG identifier	Max Node ID	Command Classes	Trigger situation
2	5	Associate with MH2910 or A2 sensors (custom command class)	Working mode, fan mode or setpoint value changes

• **Command Class supported by the device:**

Support S2:	COMMAND_CLASS_VERSION,	COMMAND_CLASS_MANUFACTURER_SPECIFIC,
COMMAND_CLASS_DEVICE_RESET_LOCALLY,	COMMAND_CLASS_POWERLEVEL,	COMMAND_CLASS_THERMOSTAT_SETPOINT,
COMMAND_CLASS_SENSOR_MULTILEVEL_V5,	COMMAND_CLASS_THERMOSTAT_MODE,	COMMAND_CLASS_THERMOSTAT_OPERATING_STATE,
COMMAND_CLASS_THERMOSTAT_FAN_MODE,	COMMAND_CLASS_THERMOSTAT_FAN_STATE,	COMMAND_CLASS_THERMOSTAT_ASSOCIATION_V2,
COMMAND_CLASS_CONFIGURATION,	COMMAND_CLASS_ASSOCIATION_GRP_INFO,	
COMMAND_CLASS_MULTI_CHANNEL_ASSOCIATION_V2,		
COMMAND_CLASS_FIRMWARE_UPDATE_MD_V5		

Not support S2:

COMMAND_CLASS_ZWAVEPLUS_INFO,	COMMAND_CLASS_TRANSPORT_SERVICE_V2,
COMMAND_CLASS_SECURITY_2,	COMMAND_CLASS_SUPERVISION

• **Z-Wave Parameter Setting:**

Number	Function	size	description	Default	Possible values
1	Temp. Unit	1	0: Celsius 1: Fahrenheit	0	0-1
2	Temp. Different Reporting	2	Unit 0.1°C 0: Disabled 3-255: n *0.1°C automatically report the temperature to the gateway when temperature variation greater than this value	5	0, 3-255
			Unit 0.1F 0: Disabled 3-255: n *0.1F automatically report the temperature to the gateway when temperature variation greater than this value	10	0,3-255
3	Automatically Sending The Report To Association Group 2 or not	1	0: Not send 1: Send	1	0-1
4	Power Failure Memory	1	When power on again: 0: Device will be in shutdown state ("OFF"); 1: Device will stay the last status before power failure.	1	0-1
5	Failed to obtain the current temperature remotely	1	When parameter 21 is set to 0: 10-255, n*10 seconds failed to obtain the current temperature remotely, will automatically close the heating or cooling valve. When parameter 21 is set to 1: this parameter is invalid. When parameter 21 is set to 2: 10-255, n*10 seconds after failed to obtain the current temperature remotely, the current temperature is automatically switched to the temperature detected by the external sensor. For example, getting the current temperature from MCOHome's MH2910 is considered to be getting the current temperature remotely.	62	10-255
6	Temp. Upper limit	1	When parameter 21 is set to 1: This parameter is invalid.	37(Celsius)	1-99
				When parameter 21 is set to 2: 10-255, n*10 seconds after failed to obtain the current temperature remotely, the current temperature is automatically switched to the temperature detected by the external sensor. For example, getting the current temperature from MCOHome's MH2910 is considered to be getting the current temperature remotely.	
7	Temp. Lower limit	1	Temperature lower limit value	5(Celsius)	0-98
				41 (Fahrenheit)	

Number	Function	size	description	Default	Possible values
8	Obtain the current temperature remotely	1	Temperature offset value (°C or °F) , accuracy 0.1 (n *0.1)	0	(-99~+99) (Celsius) (-99~+99) (Fahrenheit)
				10 (Celsius)	0-99 (Celsius)
9	Temp. Hysteresis	1	Temperature hysteresis (°C or °F) , accuracy: 0.1	20 (Fahrenheit)	0-99 (Fahrenheit)
				0	0-1
10	Fan Mode Option When Idle	1	1. When the fan mode is manual, maintain the current fan speed; when the fan mode is auto: maintain the low fan speed. 0: Fan off	0	0-1
11	Fan Working Mode	1	0: Fan works in both cooling and heating mode 1: Fan works only in cooling mode 2: Fan works only in heating mode 3: Fan does not work neither in cooling nor heating mode	0	0-3
12	Option For Interval Ventilation Feature	1	1:On 0:Off	0	0-1
13	Duration For Interval Ventilation	1	Duration for interval ventilation within 1 hour (unit: minute)	5	1-30
20	External Temp. Sensor Offset	1	Temperature offset value (°C or °F) , accuracy 0.1 (n *0.1)	0	(-99~+99) (Celsius) (-99~+99) (Fahrenheit)
21	Current Temperature Selection	1	0: Connect to other devices remotely to obtain the current temperature (for example, connect to association group 2 of MCOHome MH2910 for mutually associated). 1: The external sensor detects the temperature. 2: First obtain the current temperature from MCOHome's MH2910. If the current temperature could not be obtained from MCOHome's MH2910 within the time period set from Parameter 5, it will automatically switch to the external sensor to detect the temperature.	2	0-2
22	Anti-Freeze Protection Function	1	1:ON 0:OFF Default protection temperature range: (5.0°C - 8.0°C) Anti-freeze feature is only valid in heating mode, when temperature drops to 5.0°C , anti-freeze feature is enabled and start heating, when temperature rise to 8.0°C , anti-freeze feature is disabled and stop heating.	0	0-1
255	Factory Restore	1	1: Restore factory setting 0: Invalid	0	0-1

1-Year Limited Warranty

We warrant this product to be free from defects in material and workmanship under normal and proper use for one year from purchase date of the original purchaser. We will, at its option, either repair or replace any part of its products that prove defective by reason of improper workmanship or materials. This limited warranty does not cover any damage to this product that results from improper installation, accident, abuse, misuse, natural disaster, insufficient or excessive electrical supply, abnormal mechanical or environmental conditions, or any unauthorized disassembly, repair or modification. This limited warranty shall not apply if: (i) the product was not used in accordance with any accompanying instructions, or (ii) the product was not used for its intended function. This limited warranty also does not apply to any product on which the original identification information has been altered, obliterated or removed, that has not been handled or packaged correctly, that has been sold as second-hand or that has been resold contrary to Country and other applicable export regulations.